

Welcome!

We greatly appreciate your purchase of the PNP400 Pop 'N Plug Tower. We are sure you will find it reliable and simple to use. Superior performance for the right price, backed by solid technical and customer support is what ALTINEX has to offer.

We are committed to providing our customers with Signal Management Solutions® to the most demanding audiovisual installations at competitive pricing and we welcome you to join the ranks of our many satisfied customers throughout the world.

1. Precautions and Safety Warnings

Please read this manual carefully before using your PNP400 and keep it handy for future reference. These safety instructions are to ensure the long life of your PNP400 and to prevent fire and shock hazards. Please read them carefully and heed all warnings.

1.1 General

- There are no user serviceable parts inside. Qualified ALTINEX service personnel must perform all service on the PNP400.

1.2 Installation Precautions

- Place the PNP400 on a flat, leveled surface in a dry area away from dust and moisture.
- To prevent fire or shock, do not expose this unit to water or moisture. Do not place in direct sunlight, near heaters, or heat-radiating appliances, or near any liquid. Exposure to direct sunlight, smoke, or steam can harm internal components.
- Handle the PNP400 carefully; dropping or jarring can cause damage.
- Do not pull any cables that are attached to the PNP400.
- Do not place heavy objects on top of the PNP400.
- Do not use excessive force to push down on the top of the unit.

2. Installation Procedures

- Step 1. Refer to the ALTINEX website, www.altinex.com, to download the latest templates and instructions for tabletop cutting requirements and installation. In order to do this, locate the PNP400 on the website and go to its detail page. The links to the templates, user's guide, and more are on the left-hand side of the screen. The table can be 0.25-4.0 in (6-102 mm) thick.
- Step 2. Print all installation information for the PNP400, including the templates and any detailed instructions.
- Step 3. Mark the table's surface to indicate the correct positioning of the unit. The face of the unit is typically parallel to the longest sides of the tables.
- Step 4. Cut an opening into the table's surface. This operation should be performed by experienced professionals in order to insure accuracy and to be aesthetically pleasing. Always confirm dimensions before cutting to insure that specifications have not changed.
- Step 5. Lower the PNP400 into the opening in the table and make sure the bezel of the unit sits evenly in the table.
- Step 6. From under the table, insert the mounting brackets into the slots on the side of the unit. See Diagram 6 of the online manual for details. Place the brackets (one on each side) at the desired height for the table thickness and secure them to the bottom of the table using the thumb screws provided.
- Step 7. Secure the power cord using the cable clamp provided. Pass the power cord (if any) from the bottom of the housing and attach it to the table leaving a service loop beneath the unit. Before tightening the clamp, open and close the unit from the top several times. Set the service loop for smooth operation only. Do not leave excessive cable hanging below the table.
- Step 8. Secure PNP400 signal cables separate from the power cord. All cables should have a service loop to allow the unit to open and close easily.
- Step 9. Once you have connected power and the proper cables to the unit, you may raise the unit. To raise the PNP400 into position, press the top of the unit.
- Step 10. To lower the PNP400, push on the top of the unit until it locks into place. Do not use excessive force to press down on the pop-up.

3. Limited Warranty/Return Policies

Please see the ALTINEX website at www.altinex.com for details on warranty and return policies.

- Do not place fingers inside the PNP400 because of sharp edges inside.
- To turn off main power, disconnect AC cords from power outlets.
- Use wall outlets with a Ground Fault Circuit Interrupter (GFCI) for maximum protection.

1.3 Cleaning

- Unplug the PNP400 before cleaning.
- Clean only with a dry cloth. Never use strong detergents or solvents such as alcohol or thinner. Do not use a wet cloth or water to clean the unit. Do not open the unit to clean.

1.4 FCC Notice

- This device complies with Part 15 of the FCC Rules. Operation is subject to the following two conditions: (1) This device may not cause harmful interference, and (2) this device must accept any interference received, including interference that may cause undesired operation.
- This equipment has been tested and found to comply with the limits for a Class A digital device, pursuant to Part 15 of the FCC Rules. These limits are designed to provide reasonable protection against harmful interference when the equipment is operated in a commercial environment. This equipment generates, uses, and can radiate radio frequency energy and, if not installed and used in accordance with the instructions found herein, may cause harmful interference to radio communications. Operation of this equipment in a residential area is likely to cause harmful interference in which case the user will be required to correct the interference at his own expense.
- Any changes or modifications to the unit not expressly approved by ALTINEX, Inc. could void the user's authority to operate the equipment.

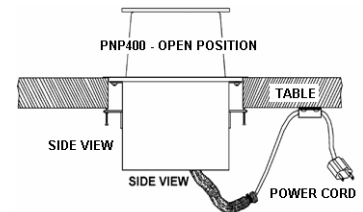

4. Technical Specifications

Specifications are subject to change. See www.altinex.com for up-to-date information.

Mechanical	PNP400 (standard)
Maximum Table Thickness	4.00 in (102 mm)
Minimum Table Thickness	0.25 in (6 mm)
Height Above Table (open)	2.909 in (74 mm)
Height Below Table Surface	5.760 in (146 mm)
Base Width	6.674 in (170 mm)
Base Depth	4.840 in (123 mm)
Finish	Black
T° Operating	10°C-35°C
T° Maximum	50°C
Humidity	90% non-condensing

Table 1. PNP400 Mechanical

5. About Your PNP400

The PNP400 Interconnect Tabletop Solution is designed for installation into a conference room table. The PNP400 provides a means of connecting audiovisual, network, and power sources into a presentation system. It is ideal for use with ALTINEX computer video interfaces like the VA6804FC. The PNP400 can "pop up" into a raised position to provide access to connectors, or it can be lowered into a table when not in use. The PNP400 uses a tower-type construction with a gas spring to raise the interface into position above the tabletop.

The PNP400 Interconnect has two openings on either side of the unit, servicing both sides of a table. Several optional sectional plates are available for the following: AC power, computer video (15-pin HD), composite video (RCA), audio (RCA), computer audio (3.5 mm stereo), phone/modem (RJ-11), RS-232 (9-pin D-sub), network (RJ-45), etc. Contact the ALTINEX Sales Department for additional information regarding optional connectors.

The PNP400 Interconnect is designed for use with tables ranging from 0.25-4.0 in (6-102 mm) thick. The PNP400 comes in a standard matte black finish. Custom finishes for the top of the PNP400 allow the unit to accent any tabletop and are available on a custom order basis for an additional charge.

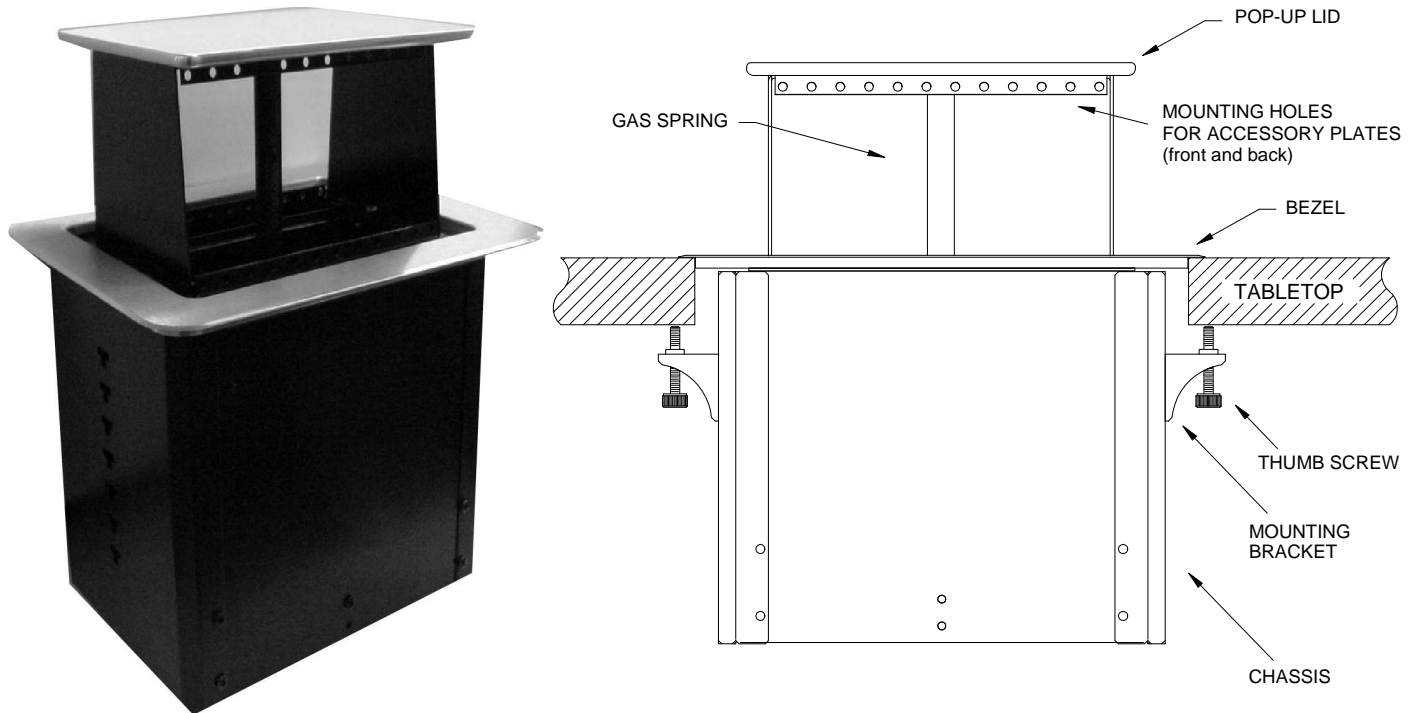

6. Application Diagrams

Diagram 1: Typical Setup

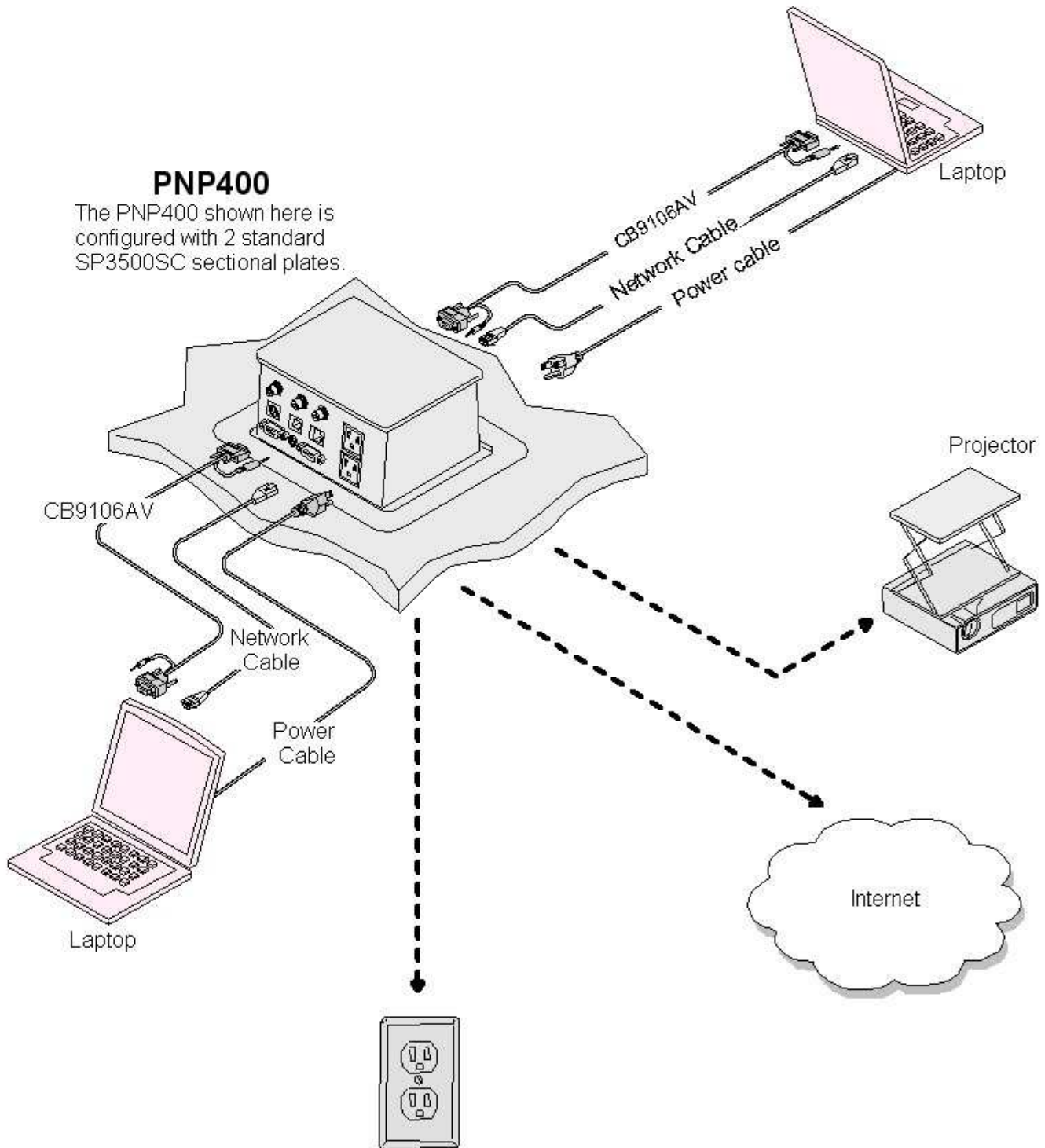

Diagram 2: Cutout

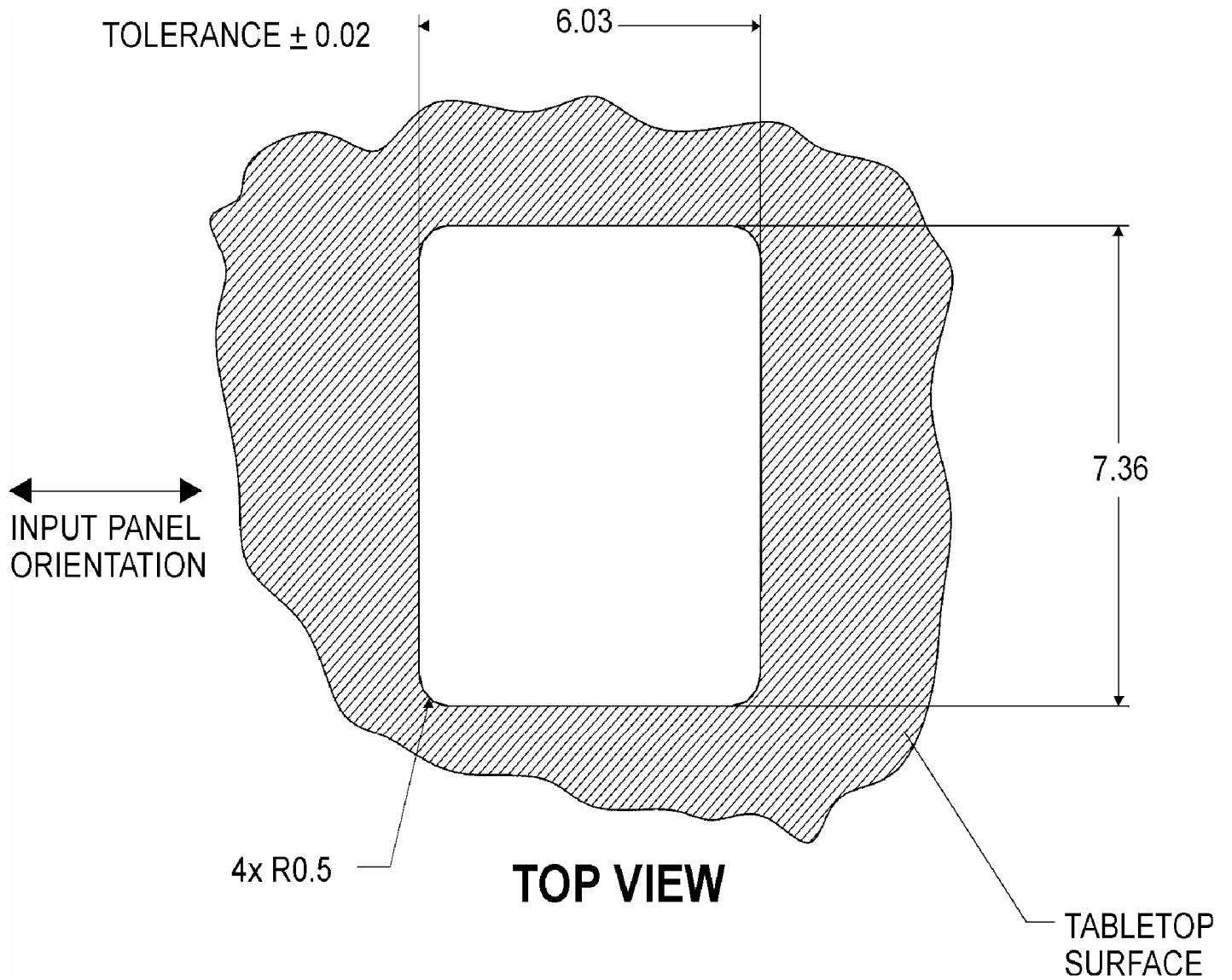

Diagram 3: Top View

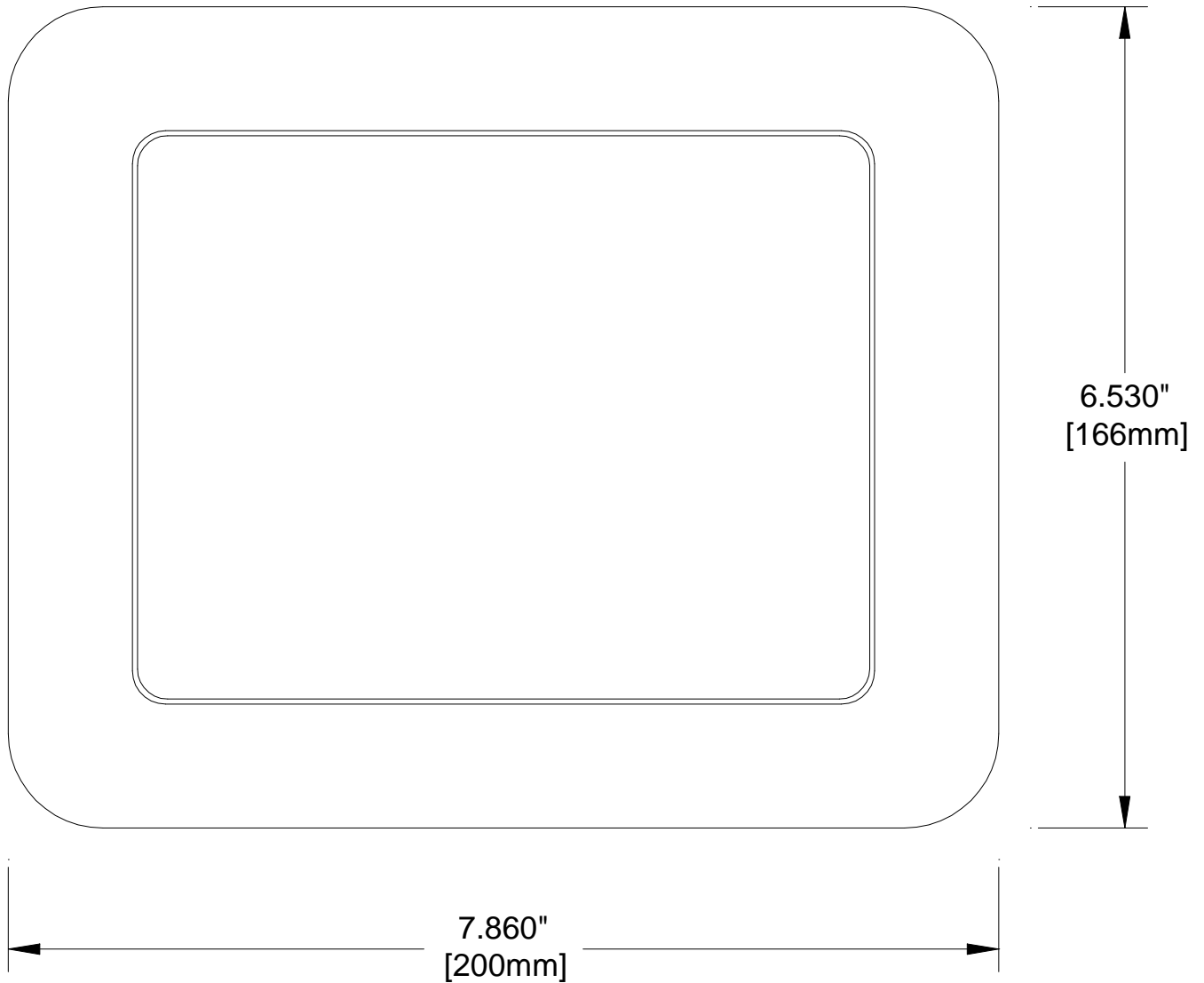

Diagram 4: Front View

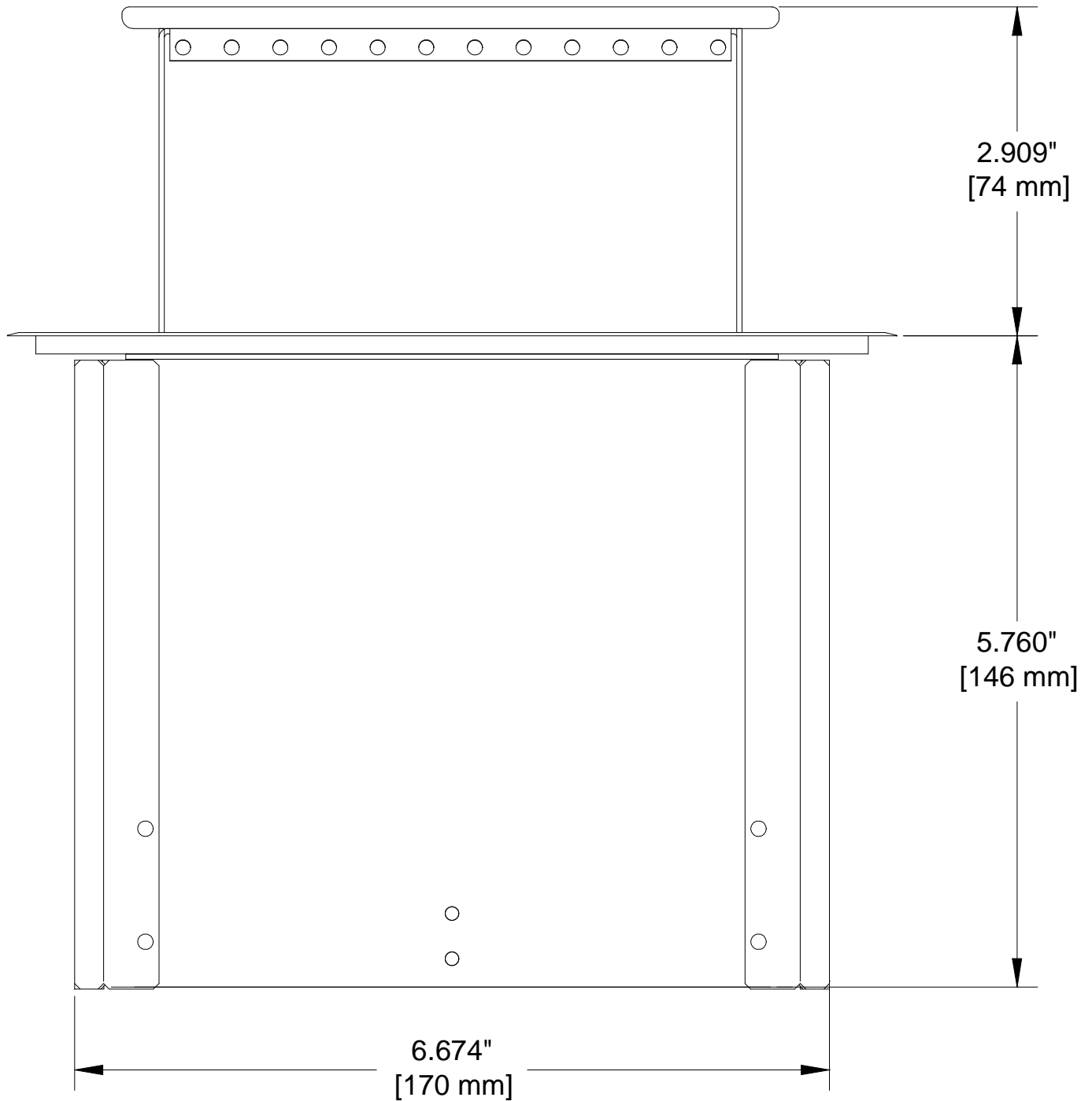

Diagram 5: Side View

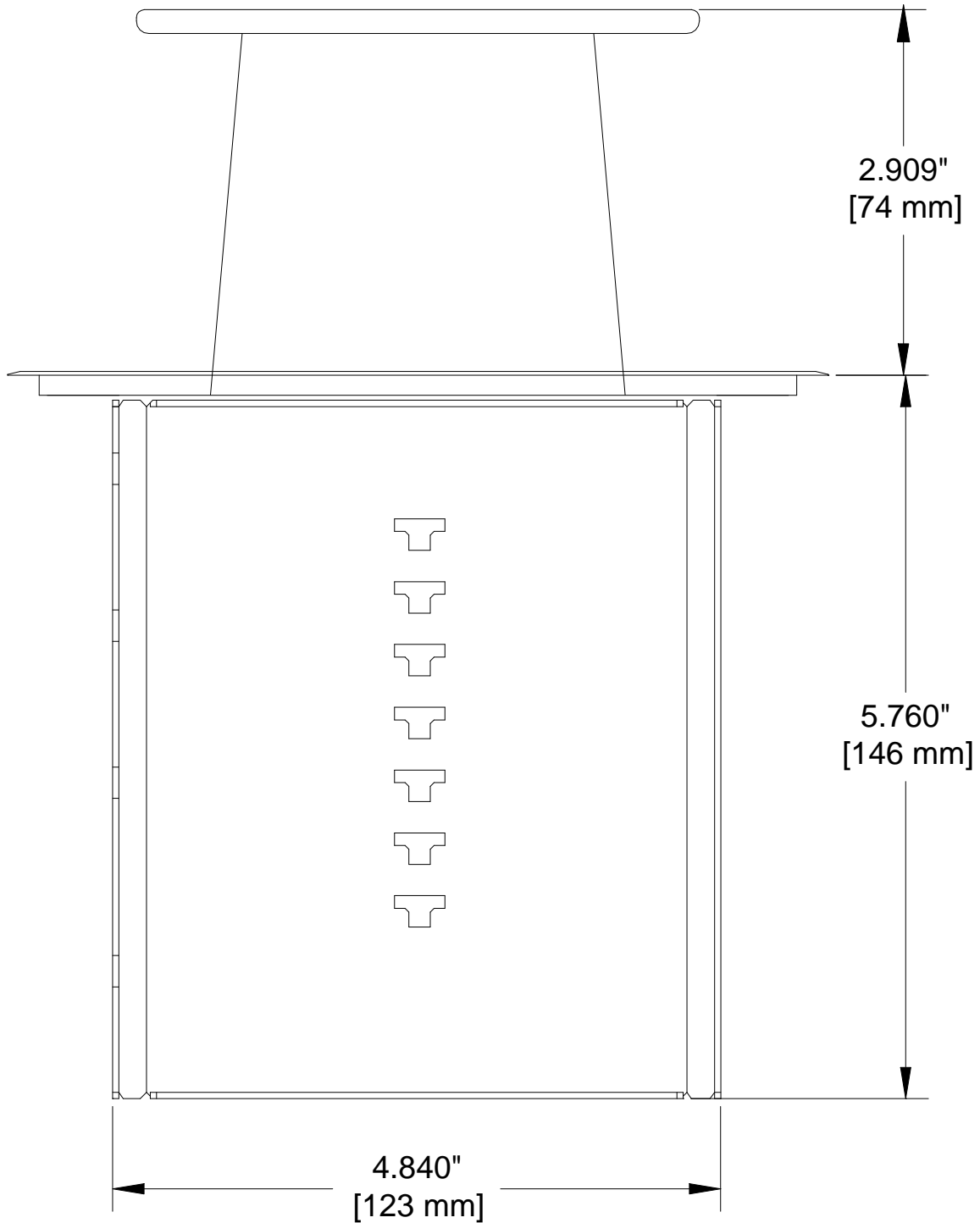

Diagram 6: Mounting

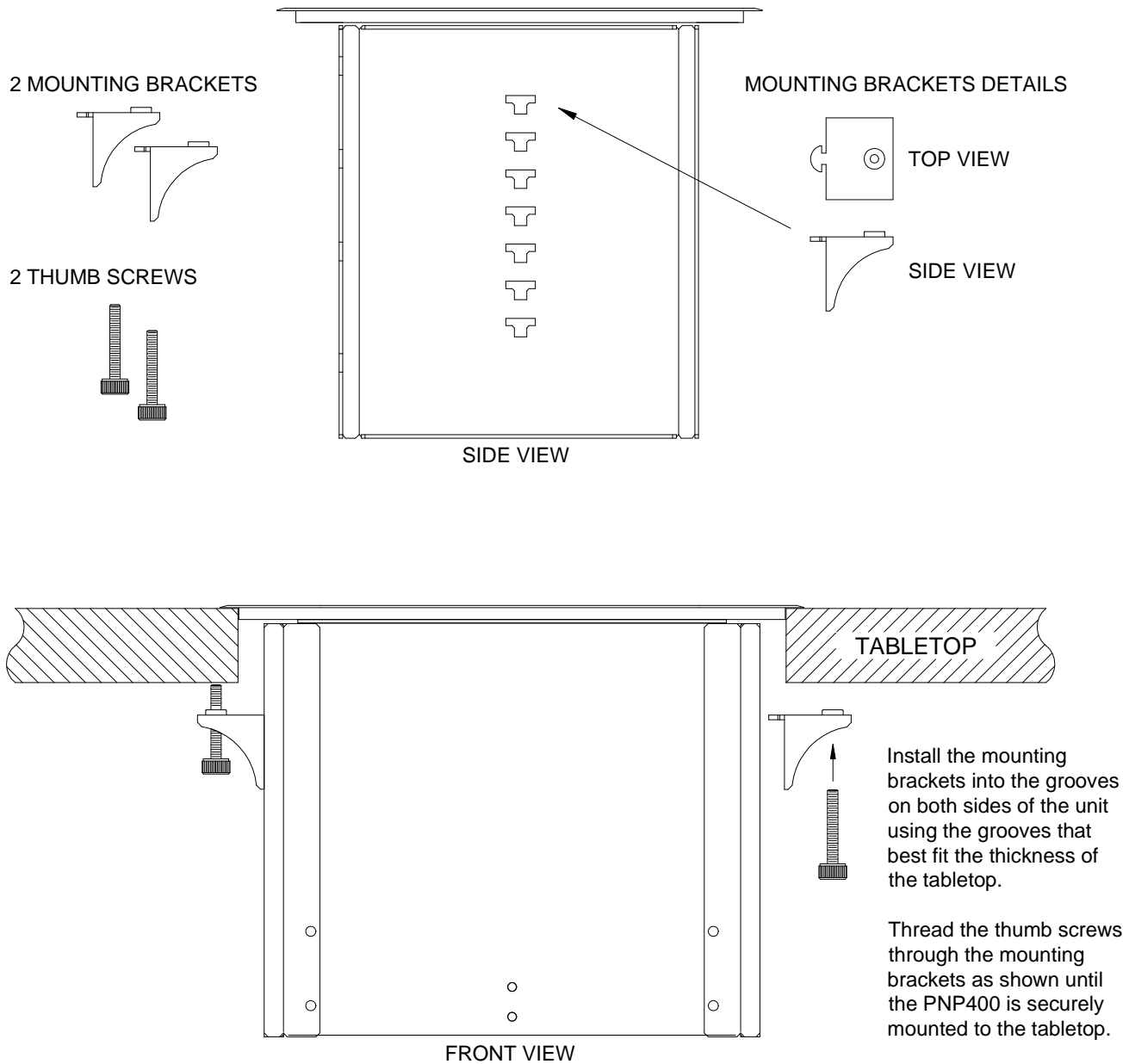
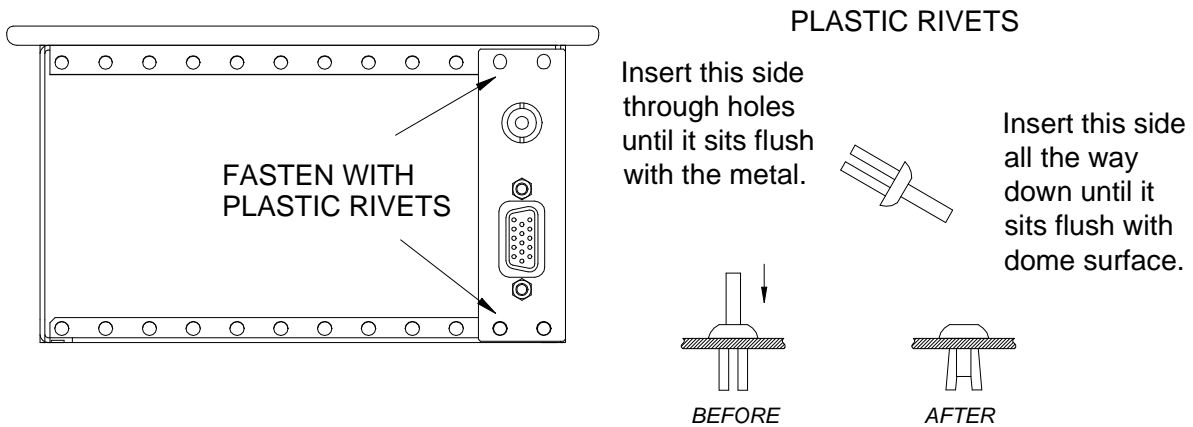
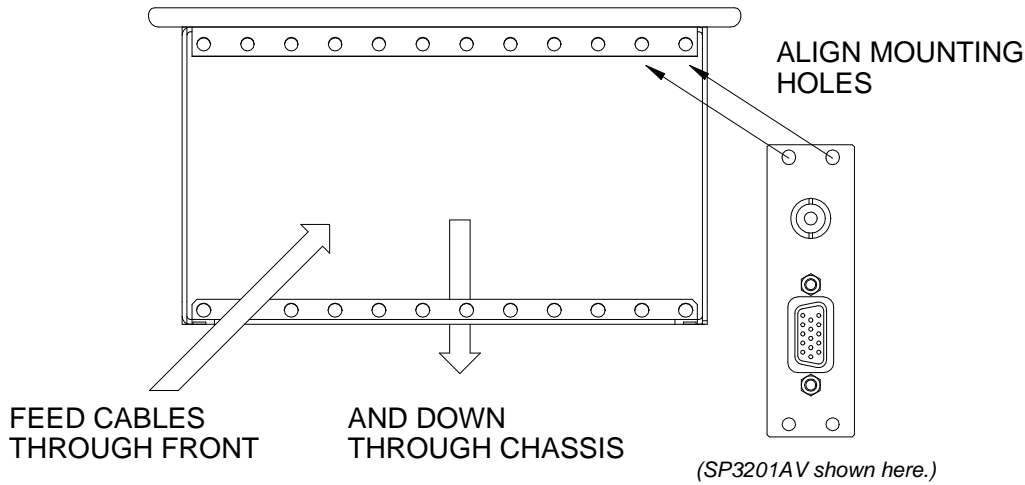

Diagram 7: Accessory Installation



- 1 Feed any cables attached to the sectional plate through the front of the PNP400, then down through the opening in the bottom of the chassis. Make sure the cables exit the chassis on the same side as the plate. They should NOT cross over the center of the unit.
- 2 Align the mounting holes of the sectional plate and PNP400 chassis.
- 3 Use the plastic rivets supplied with the sectional plate to fasten the sectional plate to the chassis. A rivet tool is supplied with the PNP400.

NOTE: The plastic rivets may be removed by pressing the center pin all the way through the material using a small screwdriver. Then use small pliers to remove the plastic, being careful not to scratch the metal.

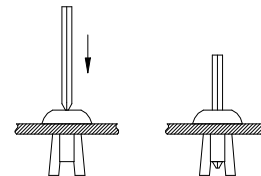

Diagram 8: Cables/Accessories

Model No.	Description
Cutout Covers	
CVR1001	Cover for PNP/TNP cutouts
Sectional Plates	
SP2107US	Dual AC Power Outlet for United States & Canada with 2 slots and 12 ft (4 m) metal conduit
SP2201UK	AC Power Outlet for United Kingdom, Singapore & Hong Kong
SP2301CE	AC Power Outlet for Continental Europe
SP2401AU	AC Power Outlet for Australia & New Zealand
SP3102EP	Dual, Empty Snap-in Ports with 1 slot
SP3103EP	Dual, Empty Ortronics CAT-6 Snap-in Ports with 1 slot
SP3201AV	15-pin HD-Female to Male + 3.5 mm Stereo Female to Male
SP3202AV	15-pin HD-Female to Female Gender Changer + 3.5 mm Stereo Female to Terminal Block
SP3204AV	4-pin Mini DIN + RCA Female 3.5 mm Stereo with 1 slot (universal plate for PNP400)
Replacement Parts	
AC401-303	Gas Spring for PNP400 Series

7. Operation

7.1 Install Sectional Plates

Install sectional plates in the empty slots on each side of the PNP400 until the plates snap into place. Secure the plates using the plastic, removable rivets as shown in Diagram 7.

8. Troubleshooting Guide

We have carefully tested and found no problems in the supplied PNP400; however, we would like to offer suggestions for the following:

- Please make sure that the highest quality video, audio, network, and telephone cables or connectors are used.
- If there has been damage, then do not use the PNP400 unit. Immediately contact the ALTINEX Sales Department to have the unit repaired.